

System Data Sheet

Disboxid Parkhaus-System OS 8

Floor coating system to directive RiLi-SIB 2001 of DAfStb. For parking and driving surfaces in underground car parks and parking garages. For roofed over, trafficable surfaces without crack bridging.



System Description

Disboxid Parkhaus-System OS 8

The Disboxid PGS-System OS 8 is used for coating interior floor spaces in underground car parks and parking garages, when no crack bridging is required. The system has a layer thickness of 2.5 mm and consists of 2 system products.

System	Product
Priming coat	Disboxid 961 EP-Grund, filled with Disboxid 942 Mischquarz
Top coat	Disboxid 464 EP-Decksiegel

Field of Application
Product Base / Vehicle

Suitable for interior use on horizontal parking and driving areas as well as ramps.

Primer: Disboxid 961 EP-Grund

Low viscous, specially formulated liquid 2-component epoxy resin, free of Bisphenol A and B-based epoxy resins, total solid as per "Deutsche Bauchemie".

Coat: Disboxid 464 EP-Decksiegel

Pigmented, 2-component epoxy resin, free of Bisphenol A and B-based epoxy resins, total solid as per "Deutsche Bauchemie".

Gloss Level

(top coat) Glossy, G1 according to DIN EN 13 300 in accordance with EN ISO 2813

Technical Data

	Disboxid 961 EP-Grund	Disboxid 464 EP-Decksiegel
Density	Approx. 1.1 g/cm ³	Approx. 1.5 g/cm ³
Mixing Ratio Base Hardener	2 parts by wt. 1 part by wt.	4 parts by wt. 1 part by wt.
Consumption	Approx. 800 g/m ² + Approx. 800 g/m ² Disboxid 942 (quartz sand) according to the respective roughness additionally: 0.5 mm:dc**** of 0.3 kg/m ² 0.3 kg/m ² Disboxid 942 (quartz sand) 1.0 mm: dc**** of 0.45 kg/m ² + 0.45 kg/m ² disboxid 942 (quartz sand) Scattering/strewing sand: 1.5 to 2 kg/m ² Disboxid 943 (quartz sand) mixed 1 : 1 with Disboxid 944 (quartz sand)	Approx. 700-900 g/m ² **
Workability *	approx. 20 Min.	approx. 45 Min.
Drying Time * Recoatable Walkable Mechanically stressable Completely cured	after approx. 8 hours after approx. 8 hours – –	after approx. 16–24 hours after approx. 16 hours approx. 3 days approx. 7 days
Application Temperatur Minimum Maximum	10° C 30° C	10° C 30° C
Abrasion to Taber (Skid-Resistance-Tester)	60 Skt.	
Crack Bridging Class	none	
Layer Thickness according to DIN EN 13501-1	B _{ff} -s1	
Layer Thickness	≥ 2.5 mm	

* Guide values at 20° C and 60 % relative humidity.

** The required quantity of top coating correlates with the roughness of the substrate and/or the temperature at the point of application as well as the chosen tools

*** Observe the additional surface roughness according to RiLi-SIB of DAfStb.

**** additional layer thickness

Package Size / Colours

Product	Package Size	Colour
Primer: Disboxid 961 EP-Grund	25 kg container: 16.67 kg tin hobbock (base material) 8.33 kg tin hobbock (hardener) 600 kg container 200 kg barrel (base material) 2x 200 kg barrel (hardener) 1x	Transparent
Coat: Disboxid 464 EP-Decksiegel	30 kg container: 24 kg tin hobbock (base material) 6 kg tin hobbock (hardener)	Gravel Grey * Stone Grey *

* Special tints for top coat are available on request.

Note: Discolouration and chalking effects may occur with weathering and UV light exposure. The pigmentation in, e.g. coffee, red wine or leaves (organic dyestuffs) and various chemicals, e. g. disinfectants, acids, etc., may cause discolouration. Scratch marks may appear on the surface due to continued rubbing/sliding. The functional capability of the coating will not be affected by these changes.

Storage

Product	Type	Duration
Primer: Disboxid 961 EP-Grund	cool, dry, but frost-free	12 month, originally closed
Coat: Disboxid 464 EP-Decksiegel	cool, dry, but frost-free	24 month, originally closed

If temperatures are low, the material should be stored at 20° C before application.

Application

Suitable Substrates

All types of interior mineral substrates. The substrate must be dry, sound, dimensionally stable, solid and free from loose particles, dust, oils, fats/greases, skid marks (wear debris) and all materials that may prevent good adhesion. Cementitious, synthetic resin tempered flow mortars must be checked for compatibility by a trial application, if necessary. The adhesive tensile strength of substrates must be 1.5 N/mm² for an average, the lowest individual value being min. 1.0 N/mm². The substrates must have achieved their equivalent humidity: Concrete and cement-based composition floor / screed max. 4 % by wt. rising damp / moisture must be avoided if Disboxid 961 EP-Grund is applied.

Substrate Preparation

Prepare the substrate by suitable means, like e.g. shot-blasting (peening) or milling, fulfilling the above mentioned requirements. Always remove existing 1-component coatings and loose 2-component coatings. Glazed substrates and rigid existing 2-component coatings must be cleaned and roughened or flattened by blasting or must be primed with Disboxid 481 EP-Uniprimer. Repair spallings and defects in the substrate with Disbocret®-PCC mortars or Disboxid EP mortars, filling flush with the surface.

Preparation

Primer: Disboxid 961 EP-Grund:

Add the hardener to the base material. Stir intensively with a low-speed electrical paddle (agitator; max. 400 rpm) until a homogeneous and streak-free shade is achieved. Pour the mixture into a sufficiently capacious container and add mixing quartz Disboxid 942 Mischquarz. Mixing ratio: 1 : 1 parts by weight. Mix thoroughly until a homogeneous knifing filler is achieved.

Top Coat: Disboxid 464 EP-Decksiegel:

Stir up the base material, then add the hardener to the base material. Stir intensively with a low-speed electrical paddle (agitator; max. 400 rpm) until a homogeneous and streak-free shade is achieved. Pour the mixture into another clean container and stir thoroughly again. The material must not be thinned. For inclined or vertical surfaces (ramps, drive-ups, etc.), 1- 3 % by wt. of set-up agent Disboxid 952 Stellmittel must be added to the material.

Surface Coating System

Priming Filler Coat

Pour the mixture of Disboxid 961 and Disboxid 942 onto the well prepared substrate and spread uniformly using a stainless steel smoothing trowel or notched hard rubber wiper. Cover the freshly applied priming coat with a surplus of quartz sand Disboxid 943, mixed with Disboxid 944 in a 1 : 1 ratio.

Consumption:

Disboxid 961 EP-Grund approx. 800 g/m²
 Disboxid 942 Mischquarz approx. 800 g/m²

according to the respective roughness additionally:

0.5 mm: dc**** of 0.30 kg/m² + 0.30 kg/m² Disboxid 942 (quartz sand)
 1.0 mm: dc**** of 0.45 kg/m² + 0.45 kg/m² Disboxid 942 (quartz sand)

Scattering/strewing quartz sand

Disboxid 943 Einstreuquarz approx. 750 -1000 g/m²
 Disboxid 944 Einstreuquarz approx. 750 -1000 g/m²

Note: If necessary, prime highly rough-textured and highly absorbent substrates with Disboxid 961 EP-Grund in the flow coating method, filling all pores, before applying the priming filler coat.

Top / Finishing Coat

Apply an even coat of Disboxid 464 EP-Decksiegel crosswise with a medium pile roller onto the sand-treated priming filler coat.

Consumption:

Disboxid 464 EP-Decksiegel approx. 700-900 g/m²

Note: Connections from rising building elements to floors must be treated as grooves (see pictures 1 and 2). Joints on the floors must be treated as shown in pictures 3 or 4.

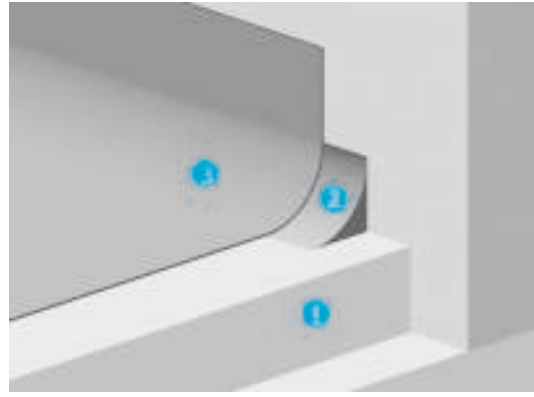

Pic. 1: Forming of grooves connecting floor and rising building elements

- (1) Concrete slab
- (2) Groove made of Disboxid 438 EP-Spachtel or Disboxid EP-Mörtelbelag
- (3) Coating: Disboxid Parking Garages Floor Coating System

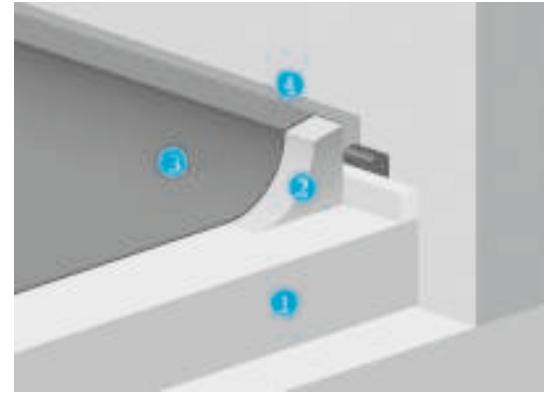

Pic. 2: Forming of grooves connecting floor and rising building elements - with integrated joint

- (1) Concrete slab
- (2) Groove made of Disboxid 438 EP-Spachtel or Disboxid EP-Mörtelbelag
- (3) Coating: Disboxid Parking Garages Floor Coating System
- (4) Sealing of joints with Disbothan 221 Fugendicht

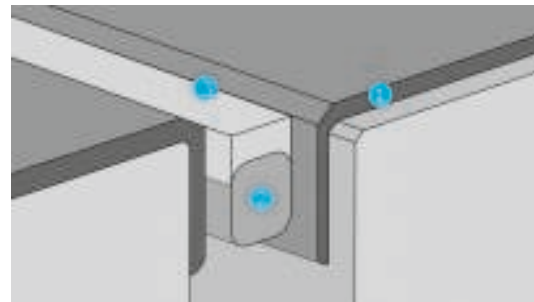

Pic. 3: Treatment of joints in floorspaces measurement and treatment of joints as per IVD Data Sheet No. 1

- (1) Coating: Disboxid Parking Garages Floor Coating System
- (2) Joint filling profile
- (3) Sealing of joints with a suitable joint sealing compound

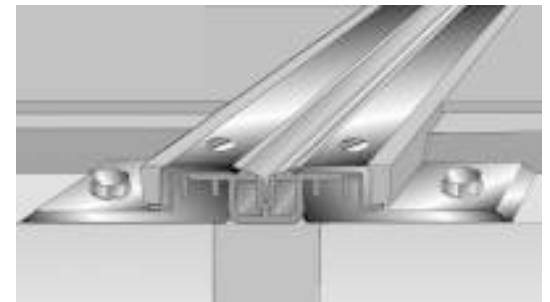

Pic. 4: Treatment of joints in floors with a ready-made joint profile.

- (1) Ready-made joint profile
- (2) Disboxid 438 EP-Spachtel or Disboxid EP-Mörtel (epoxy mortar)
- (3) Coating: Disboxid Parking Garages Floor Coating System

Waiting Time	At 20° C respect a waiting time of minimum 8 hours between the application of priming filler coat and finishing coat. The given period will be shortened, when temperatures are higher, and longer at lower temperatures.
Working Temperature	Material, ambient, and substrate temperature must remain at a min. of 10° C and max. 30° C. Relative humidity must not exceed 80 %. Substrate temperature should always be min. 3° C above the dew point temperature.
Drying Time	At 20° C and 60 % relative humidity, walkable after approx. 16 hrs., ready for mechanical stress after approx. 3 days, and completely cured after approx. 7 days. Lower temperatures lengthen the hardening process. During hardening (approx. 24 hrs at 20° C), the applied material should be protected from moisture to avoid irregularities in the surface and diminished adhesion. Especially when applying below 15° C the surfaces have to be protected against humidity (also air moisture) during the hardening as whitening might occur.
Tool Cleaning	Clean tools immediately after use or during longer breaks with thinner Disboxid 419.

Advice

Special hazards/risks, safety advice, Giscodes, disposal, VOC and CE labelling to EN 13 813 for each system product:

Follow the corresponding Technical Information:

Disboxid 961 EP-Grund
Disboxid 964 EP-Decksiegel

German Certificates

- 1-1092 Allgemeines bauaufsichtliches Prüfzeugis OS 8
(say: General building inspection test certificate OS 8)
by Polymer-Institut, Flörsheim
- 1-1201 Nachweis der Rutschhemmung R12 V6 OS 8
(say: Testing of anti-slip property R12 V6 OS 8)
by Berufsgenossenschaftliches Institut, St. Augustin
- 1-1191 Prüfung des Brandverhaltens nach DIN EN 13 501-1, B_{fl-s1}
(say: Testing of the fire resistance according to
DIN EN 13 501-1, B_{fl-s1} by Prüfinstitut Hoch, Fladungen)

Further Details

See Safety Data Sheets (MSDS). Follow the application references while applying our products. During the application of the products building protection application instructions as well as the Caparol Cleaning and Maintenance instructions for floors have to be observed.

Technical Assistance

As it is impossible to list herein the wide variety of substrates and their specific problems, please request our technical assistance in case of queries.
We will describe appropriate working methods, if a substrate not specified above is to be coated.

Customer Service Centre

Tel.: (+49) 0 61 54 / 71 17 10
Fax: (+49) 0 61 54 / 71 17 11
e-mail: kundenservicecenter@caparol.de

International Distribution: Please see www.caparol.com

System Data Sheet Disboxid Parking Garages System OS 8 · Issue: November 2011

All suggestions and application instructions herein are based on our latest technical experience. Due to the wide variety of individual project conditions, we cannot be held responsible for their content. These instructions do not release the purchaser/ applicator from his responsibility to determine the suitability of the product in consideration of the project characteristics. These instructions are to be considered void when a new edition is released. Our general conditions of sale and delivery in their latest edition apply. This document is a translation of our German System Data Sheet Disboxid Parking Garages System OS 8 · Issued: August 2010

DAW International Business: **Deutsche Amphibolin-Werke von Robert Murjahn Stiftung & Co KG** · P.O.B. 1264 · D-64369 Ober-Ramstadt · Tel. +49 6154 71-1274
Fax +49 6154 71-1264 · E-mail export@daw.de · Internet www.caparol.com